

Advanced System for Solar Tracking

MANOJ OJHA

SOEIT, Sanskriti University, Mathura, Uttar Pradesh, India

Email ld-manoj@sanskriti.edu.in

ABSTRACT: *Solar energy is a highly effective way to boost renewable energy supply. This article discusses the design and development of a microcontroller-based Solar Panel Tracking System. Given that the author has installed solar panels to satisfy our electrical demands, sunlight is a non-conventional energy source. However, because of the earth's rotation, the solar source, i.e. the sun, does not always face the plate, resulting in less power being produced. The energy panel will face the SUN until it is present, which should be within a day. The device design is depicted in the block diagram below, which includes a light dependent resistor (LDR) sensor that supplies maximum solar power to the microcontroller through an ADC that digitizes the LDR's performance. The controller then makes a choice based on the algorithm and tilts the panel with the help of a DC Motor in the direction of the LDR's highest energy. Two relays manage the system as a DC geared motor driver, and a microcontroller controls the system as the primary processor. This project is protected by a single axis and is intended for low-power and domestic uses. Regardless of motor speed, the system can track and follow the Sunlight intensity from the hardware test to acquire maximum solar power at the output. In future, this solar tracker system may be modified by adapting new technologies like Internet of things (IOT) and can be used for home purposes.*

KEYWORDS: *LDR, Microcontroller, Motor Driver, Photovoltaic Cell, Solar Panel.*

1. INTRODUCTION

Energy is the most important component in a country's development. Every day, a tremendous amount of energy is generated, transferred, transformed, and consumed in the worldwide civilization. 85 % of energy is produced from fossil fuels. Fossil fuel supplies are finite, and their usage contributes to global warming by releasing greenhouse gases into the atmosphere. To ensure a sustainable power supply and a healthy environment for future generations, there is a rising need for energy from renewable sources such as solar, wind, geothermal, and ocean tidal waves[1]. The sun is the major source of power and the fuel for most renewable energy systems, whether directly or indirectly. The photovoltaic system is one of the many renewable energy technologies that have the potential to replace traditional energy sources. A solar panel converts sun energy into electricity directly. Solar panels are mostly composed of semiconductor-based materials. Si is the primary component of solar panels, with a maximum efficiency of 24.5 %. The only method to boost a solar panel's output if high-efficiency solar panels are created is to increase the light intensity falling on it. Solar trackers are the most effective and well-tested technique for improving solar panel performance by keeping them aligned with the sun's position[2]. Solar trackers have recently gained popularity across the world as a more effective way to collect solar energy. This is a far more cost-effective alternative than purchasing extra solar panels.

The practice of designing a specific manual and/or automatic system that meets the demands of the client is known as Mechatronics system design. A designer considers and evaluates numerous elements and product designs for specific requirements that may differ from those currently in use. Certain criteria, such as size, shape, material, load, and application type, are required for every electronic/mechanical component[3]. Sensor type, rotation technique, motor

weight, kind of photovoltaic panel, type of microcontroller utilised, component selection, and other aspects all impact the design of a solar tracking system.

India is a developing country that gets its energy from a range of commercial and non-commercial sources. In recent years, it has been highlighted that fossil fuel supplies are fast decreasing and that the era of fossil fuels, particularly oil and natural gas, is gradually coming to an end. The most severe issue with traditional energy sources is their negative environmental impact[4]. It is also the primary contributor to the global warming problem, which is becoming a major worry. According to the latest assessment from the Intergovernmental Panel on Climate Change (IPCC), increasing methane and nitrous oxide concentrations have caused global surface temperatures to rise. Solar energy, which is renewable in nature, is being employed increasingly frequently to address these concerns.

Solar energy is a clean, sustainable form of energy that is abundant in nature[5]. The sun is a massive orb of extremely hot gases heated by several types of fusion processes. The diameter of the sun is 1.39×10^6 . Because of its extended reach, the sun subtends to the earth's surface at an angle of 32 minutes (0.53°) when it is high. As a result, the beam radiation emitted by the earth's sun is nearly similar. The sun's brightness varies from the top to the bottom. The quantity of energy received by the planet from the Sun is hundreds of times larger than the total amount of commercial energy created on Earth today. As a result, thousands of years might be lived on solar energy rather than traditional sources of energy such as fossil fuels. India has 4000-5000 hours of sunlight each year, enough to create hundreds of times the country's current electricity usage. For optimum energy extraction/generation from solar energy, photovoltaic panels must be kept perpendicular to the direction of sun motion during the day.

The goal of this article is to create an automated solar tracking system that can capture all of the available solar energy and convert it to electrical energy[6]. Natural processes in the earth's crust require millions of years to produce nonrenewable sources. They're gone for good once they've been burned to create power. Burning fossil fuels produces unwelcome by-products that contaminate our environment, altering the planet's climate and endangering ecosystems. Solar electricity, on the other hand, is limitless and contains no polluting chemicals. The problem statement for this thesis is to use Light-Based Resistors, microcontrollers, and DC motors to monitor the movement of photovoltaic (PV) panels in reaction to sunlight in order to obtain the greatest amount of solar energy and convert it into electrical energy. This project's major objective is to create the concept of a sun-tracking solar system, which is a device that follows the Sun's movement independent of motor speed. In addition, using a single-axis sun tracking technology, the objective is to enhance overall power generation while simultaneously providing residential architecture. The LDR or light-based resistor was chosen as the sensor since LDR is widely used in sun-tracking systems.

Because LDR is light-sensitive, this is the case. The resistance of LDR will decrease as the light intensity of events increases[7]. The AT89S52 was chosen as the controller. ATMEL's programming will provide the driver the signal to turn on the motor. With the relay to the driver, bidirectional DC motor control was employed. The motor controller was chosen because it allows the engine to revolve in both clockwise and counterclockwise directions with ease. The DC geared motor, which has a holding torque of upto 24 kg.cm and a low rpm, is another option. Last but not least, the LM7805 is utilised to convert the input voltage from the source to the 5 V output required by the integrated circuit.

1. Benefits:

System for Solar tracking are used to steer photovoltaic panels towards the sun indefinitely, which can help you get the most out of your PV system investment. They're useful since the sun's position in the sky might fluctuate over the course of a day and throughout the year as the seasons change. From dawn until dark each day, they are most effective in areas with low horizons and shade-free locations. The tracking array will be able to take use of the year-round open access to obtain every available electron from the sun. As a result, energy output is at its peak, while energy demand rises throughout the year.

Standing-alone solar panels are a highly efficient and low-maintenance way to generate energy. Using solar tracking systems, photovoltaic panels can be continuously oriented toward the sun, which will help you get the most out of Their important since the sun's position in the sky can fluctuate slowly over the course of a day and through the seasons throughout the period of Use of a tracking device will primarily depend on how well it is placed to analyze how effectively the panels can enhance their efficacy. As a rule of thumb, they are best effective in regions with low horizons and areas that are devoid of shadow from dawn to sunset. The tracking array will be able to take use of the year-round open access to obtain every available electron from the sun. As a result, energy output is at its peak, while energy demand rises throughout the year. This is especially true during the summer months, when there are plenty of long sunny days to be had.

2. Applications:

Regardless of whether a photovoltaic (PV) or concentrated solar power (CSP) facility is required, it regulates movement in both azimuthal and zenithal directions. The components or mirrors are perfectly aligned with the angle of the sun's beams to maximize solar energy regardless of the sun's position. Solar tracking systems have up to a third higher energy yields than stationary PV systems, and the closer an installation is to the equator, the more efficiently the PV tracking systems function depending on the strength of the sunshine at the installation location. Concentrated photovoltaics and concentrated solar power applications need precise tracking of solar units in order to focus sunlight on the target medium. Photovoltaic panels, lenses, reflectors, and other optical equipment are oriented towards the sun using solar trackers. Trackers are used to coordinate the collecting system to optimize the output of energy because the location of the sun in the sky fluctuates with the seasons and time of day. Different factors must be considered while determining whether or not to employ trackers.

Solar panels are generally placed in full direct sunlight in the middle of the day, facing south in the Northern Hemisphere or north in the Southern Hemisphere. As a result, the panels are hit at an acute angle in the morning and evening, reducing the total quantity of power that may be produced each day. A solar tracker is a system that is fitted with solar panels that monitor the sun's movement through the sky, ensuring that the greatest amount of sunlight reaches the panels during the day. The cost of a solar tracker is fairly low when compared with the price of the PV solar panels. They are highly efficient, proprietary solar tracking systems with single and double axes [8].

This electrical device's main component is a microcontroller. This is where all of the operations are managed. With the help of a microcontroller, you may position the solar panel according to the strength of the sunshine. The rechargeable battery, which is utilised to store energy by the panel, is another component. The charging control's purpose is to regulate battery charging. The battery state is received by the microcontroller unit via the control panel for charge. It features two LDR sensors, one on each side. On the unit, four LDRs form and are located in

the four corners of the panel. The controller receives the output from the LDR, which detects the intensity of sunlight. The Control unit determines which way the panel should be turned to obtain the most sunlight. LDRs are also utilised in another section of the sensor, which is employed to adjust the lighting load. The server motor can rotate the panel in the desired direction. In this study, the author employed a solar panel to convert light energy into electrical energy. The Sun varies its position during the day, so the author couldn't use all of the light energy, so they created a monitoring mechanism that rotates the solar panel when the sun alters its position.

An embedded system consists of a combination of computer hardware and software, as well as perhaps external mechanical or other elements, all of which are designed to serve a specific function. Embedded systems are frequently a component of a larger, more sophisticated system. Dedicated applications are developed and embedded in systems that are intended to carry out specialized tasks. These embedded programmes must communicate with the rest of the enclosed system's components. The application's embedded components often connect with the outside non-human environment. They utilised four LDR sensors to detect light, and if the sun's position changes, the sensor changes as well. Each LDR sensor's voltage readings are sent to the microcontroller and compared to the LM324. The microcontroller compares each LDR output to each LDR output after receiving the voltage signal from any I/O pin on the controller. The motor is told to spin the solar panel on a single axis in the direction of the LDR sensor that provides the greatest voltage output when the controller discovers the highest voltage level of any LDR sensor. Figure 1 illustrates the block diagram of the solar tracking system.

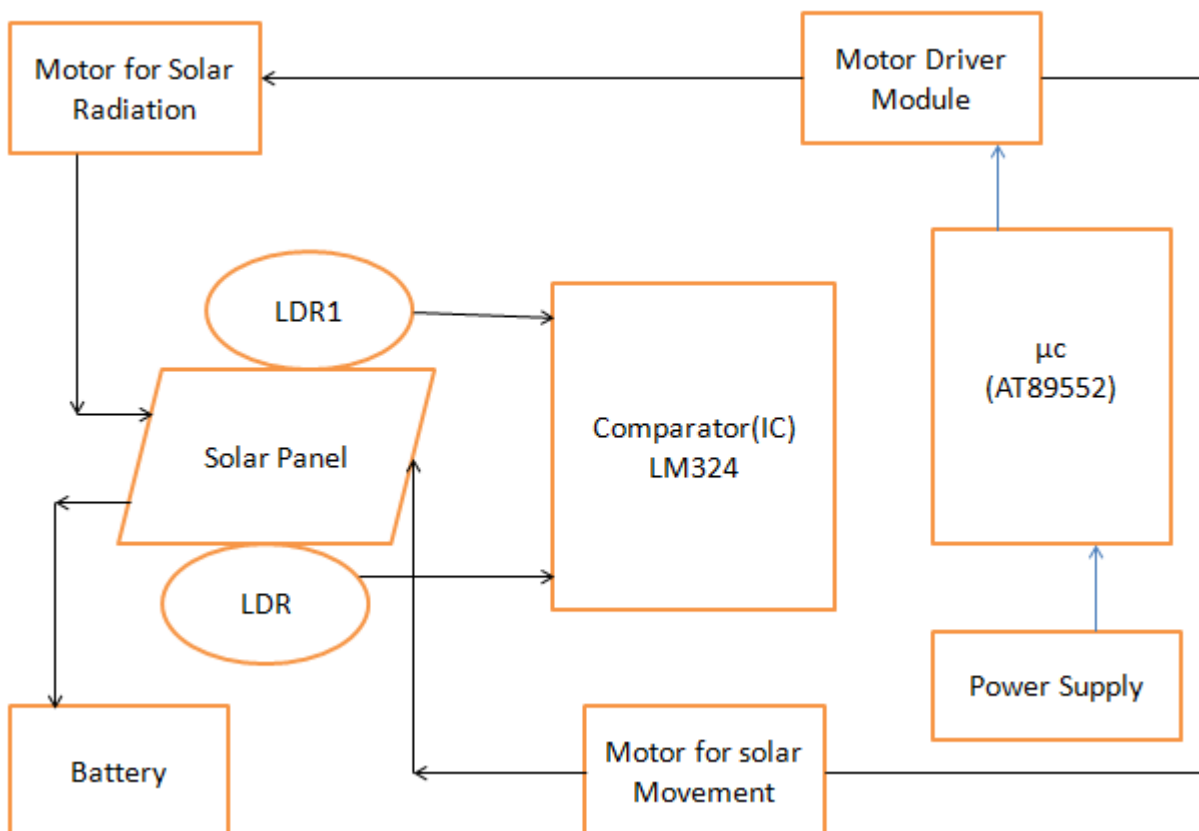

Figure 1: Illustrate The Block Diagram of Solar Tracking System.

As a result, the battery may be recharged properly using the Solar Panel, and the author can use certain electrical equipment to rotate the 12 V DC fan on a regular basis. Using two external motors and connecting them in tandem, the author can move the solar panel in any direction. By orienting the solar panel towards the direction of the sun, the whole energy of the sun is harnessed. The LDR sensor detects light and creates the highest voltage signal, which is sent to the comparator IC, as well as other sensors, to determine the voltage level generated by the comparator IC.

In an embedded system, a microcontroller is a small integrated circuit that governs a certain operation. On a single chip, a microcontroller has a CPU, memory, and input/output (I/O) peripherals. It can be used in many machines like keywords, ovens, dryers, security systems and electrical machines. A solar panel, also known as a photovoltaic (PV) module, is an installation of photovoltaic cells set in a framework. Solar panels create direct current electricity using sunlight as a source of energy. A photo resistor or a cadmium sulphide (CdS) cell is another name for a Light Dependent Resistor (LDR). A photoconductor is another name for it. LDRs are used to detect light levels in automated security lighting, for example. Their resistance reduces as the light intensity increases: an LDR's resistance is high in the dark and at low light levels, and only a small amount of current may flow through it.

2. LITERATURE REVIEW

Suneetha et al. discussed a review on Solar tracking system[8]. The greatest problem for the next half-century will be generating power from the decrease of fossil fuels. When compared to other renewable energy sources, the notion of turning solar energy into electrical energy using photovoltaic panels is at the top of the list. The watts provided by solar panels are reduced by the constant shift in the relative angle of the sun with respect to the earth. In this case, the greatest option for increasing the efficiency of the photovoltaic panel is to use a solar tracking system. Throughout the day, solar trackers bring the payload closer to the sun. The advantages and disadvantages of various types of tracking systems are discussed in detail in this paper. In comparison to other tracking systems, the azimuth and altitude dual axis tracking system is more efficient, according to the results presented in this review. However, from the standpoint of cost and versatility, a single axis tracking system is more practical than a dual axis tracking system.

Vaibhav et al. discussed a review on automatic system of solar radiation tracking[9]. Because fossil fuels are a rather short-term energy supply, an alternate energy resource is required. Solar energy is being increasingly widely used as a renewable energy source. Solar modules are commonly used to convert solar energy into electricity, although the solar energy is not entirely utilised. The efficiency of solar array systems must be increased to make solar energy more usable. Solar radiation tracking is a viable method for increasing the efficiency of solar array systems. A system that regulates the movement of a solar array so that it is always aligned with the direction of the sun is known as an automatic solar radiation tracker. For the implementation of such systems, several technologies are utilised across the world. Some of these technologies are discussed in this publication.

Mahipal et al. discussed an analysis of solar tracker system[10]. This report offers a research analysis of a solar tracker system for increasing solar panel efficiency. The act or practice of following something or someone is referred to as tracking. So, an automated solar tracker system is a device that follows the sun's light to extract the most amount of energy from it. Solar panels are always in perpendicular profile with regard to the sun light to maximize

efficiency or obtain maximum energy. Solar tracking with mirror booster and automatic cleaning system are two technologies being investigated to improve the efficiency of solar panels. Microcontroller, LDRs, stepper motor, solar panel, mirror booster, and automatic cleaning machine comprise the solar tracker system. With the aid of a stepper motor, the LDR sensor detects the sun light falling on the solar panel and spins the solar panel according to the intensity of the light. To increase efficiency, a mirror is utilised as a booster. The system is controlled by a programmed microcontroller that communicates with a sensor and a motor driver dependent on the movement of the sun.

3. DISCUSSION

The machine centers on designing the controller. The designed system was checked and some data from measuring hardware were collected and discussed. The typical solar panel was used and the intention was only to show that the built system is capable of working accordingly. For example, weather conditions are not seriously considered during hardware testing therefore the surrounding effects. In this research, researcher proposed the design and development of a microcontroller-based Solar Panel Tracking System. The device design is depicted in the block diagram, which includes an LDR sensor that supplies maximum solar power to the microcontroller through an ADC that digitizes the LDR's performance. The controller then makes a choice based on the algorithm and tilts the panel with the help of a DC Motor in the direction of the LDR's highest energy. Two relays manage the system as a DC geared motor driver, and a microcontroller controls the system as the primary processor. The future of this solar tracking system is bright as it can be used for home purposes and further, it will be modified by adapting new technologies.

4. CONCLUSION

The Axis Solar Tracking System has a single prototype model that has been successfully developed. The designed system focuses on the controller part, with the primary concern being to design appropriate circuits that can control the direction of rotation of the DC-gear motor without taking the motor's speed into account. Regardless of the motor speed, the machine is capable of monitoring and following Sunlight intensity in order to obtain full solar power. The motor speed is not a significant issue as distinctive of the proposed system because the DC-gear motor has a low output rated speed and a high output rated torque. As a result, any DC-gear motor can be used in this system, regardless of the motor speed control unit, as long as the motor's speed and torque meet the specifications. In the future, the built system concept may be used to develop alternative energy sources in the home, especially for non-critical and low-power appliances.

REFERENCES

- [1] R. S. Zulkafli, A. S. Bawazir, N. A. M. Amin, M. S. M. Hashim, M. S. A. Majid, and N. F. M. Nasir, "Dual axis solar tracking system in Perlis, Malaysia," *J. Telecommun. Electron. Comput. Eng.*, 2018.
- [2] H. Fathabadi, "Novel high accurate sensorless dual-axis solar tracking system controlled by maximum power point tracking unit of photovoltaic systems," *Appl. Energy*, 2016, doi: 10.1016/j.apenergy.2016.03.109.
- [3] S. Obara, K. Matsumura, S. Aizawa, H. Kobayashi, Y. Hamada, and T. Suda, "Development of a solar tracking system of a nonelectric power source by using a metal hydride actuator," *Sol. Energy*, 2017, doi: 10.1016/j.solener.2017.08.056.
- [4] A. Singh and N. Aphiratsakun, "AU solar tracking system," 2015, doi: 10.1109/ECTICon.2015.7206970.
- [5] E. Kabir, P. Kumar, S. Kumar, A. A. Adelodun, and K. H. Kim, "Solar energy: Potential and future prospects," *Renewable and Sustainable Energy Reviews*. 2018, doi: 10.1016/j.rser.2017.09.094.
- [6] F. Abdel-Hady, "DESIGN OF SOLAR TRACKING SYSTEM," *Int. J. Eng. Technol.*, 2018, doi:

-
- 10.21817/ijet/2018/v10i2/181002023.
- [7] A. Makwana and D. Lad, "Dual Axis Solar Tracking System using 5-LDR sensor," *Int. Res. J. Eng. Technol.*, 2017.
- [8] S. Racharla and K. Rajan, "Solar tracking system—a review," *Int. J. Sustain. Eng.*, vol. 10, no. 2, pp. 72–81, 2017, doi: 10.1080/19397038.2016.1267816.
- [9] P. V. J. Babrekar, M. S. Kurhekar, K. K. Mulmule, and D. B. Mohade, "Review On Automatic Solar Radiation Tracking System," vol. 7, no. 2, pp. 625–628, 2016.
- [10] D. D. C. Soni, Mahipal, "Analysis of Solar Tracker System to Increase the Efficiency of Solar Panel : A Study," vol. 1, no. 9, pp. 6–9, 2018.